



Peii Chen, PhD;
Nicole Spaldo, MS, OTR/L ;
C. Priscilla Galarza ;
Adrienne Giordano;
Kimberly D. Heckert, MD;
Anna M. Barrett, MD



Visuospatial Rehabilitation After Right Hemisphere Stroke

More Than Repetition

Picture It.

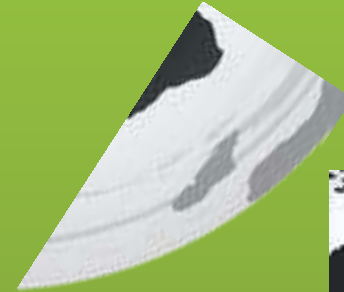
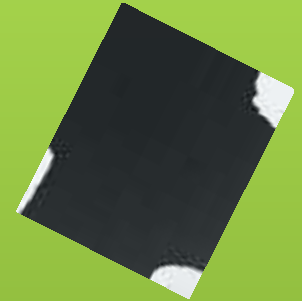

Background

- Right Hemisphere and visuospatial processing
- Global processing
 - Understanding the “big picture”
 - Predominant method for processing information¹
- Severely disrupted after RH CVA²



1. Kimchi, 1992

2. Delis et al., 1986; Frank&Landeira-Fernandez, 2008; Lange et al., 2000; Poreh&Shye, 1998; Warrington et al., 1966

So what IS the big idea?

- Healthy brains use this approach spontaneously¹
- Visuospatial Encoding and Recall in Practice
 - Finding your way to the bathroom
 - New phone numbers
 - Names and faces
 - Poor recall not traditionally considered a visuospatial processing disorder

1. Madigianai et al., 1998; Navon, 1977; Newman and Krikorian, 2001; Poirel et al., 2008; Rossano&Hodgson, 1994

So what do we do?

- Current Treatment for Visual Memory Impairment
 - Therapist driven*
 - Drills
 - Mnemonic devices
 - Story telling
 - Association
 - Compensation
- This Study's Strategy
 - Subconsciously driven*
 - Global encoding strategy
- Purpose
 - Compare current methods to a global encoding strategy

Hypothesis

- Previous research¹
 - Effectiveness of global processing training
 - No control for effect of repetitive practice
- Structured learning protocol or repetition?
 - What works and what doesn't?

1. Eslinger, et al., 1995

Demographics

	Age/ Gender	Days Post Stroke	Years of Education	Mini Mental State Exam	Behavioral Inattention Test	Geriatric Depression Scale	Barthel Index
P1	66/F	27	16	29	145	1	70
P2	75/F	63	14	30	135	4	95
P3	67/F	24	14	29	144	3	80
P4	67/M	65	8	27	142	4	50
Mean	68.75	44.75	13	28.75	141.5	3	73.75

Methodology

- Four right hemisphere stroke survivors, all right handed, randomly assigned
 - P1 and P2
 - Global-to-local encoding strategy training
 - P3 and P4
 - Non-structured repetition
- Outcome Measure
 - Ray-Osterreith Complex Figure (ROCF)

Rey-Osterrieth Complex Figure (ROCF)

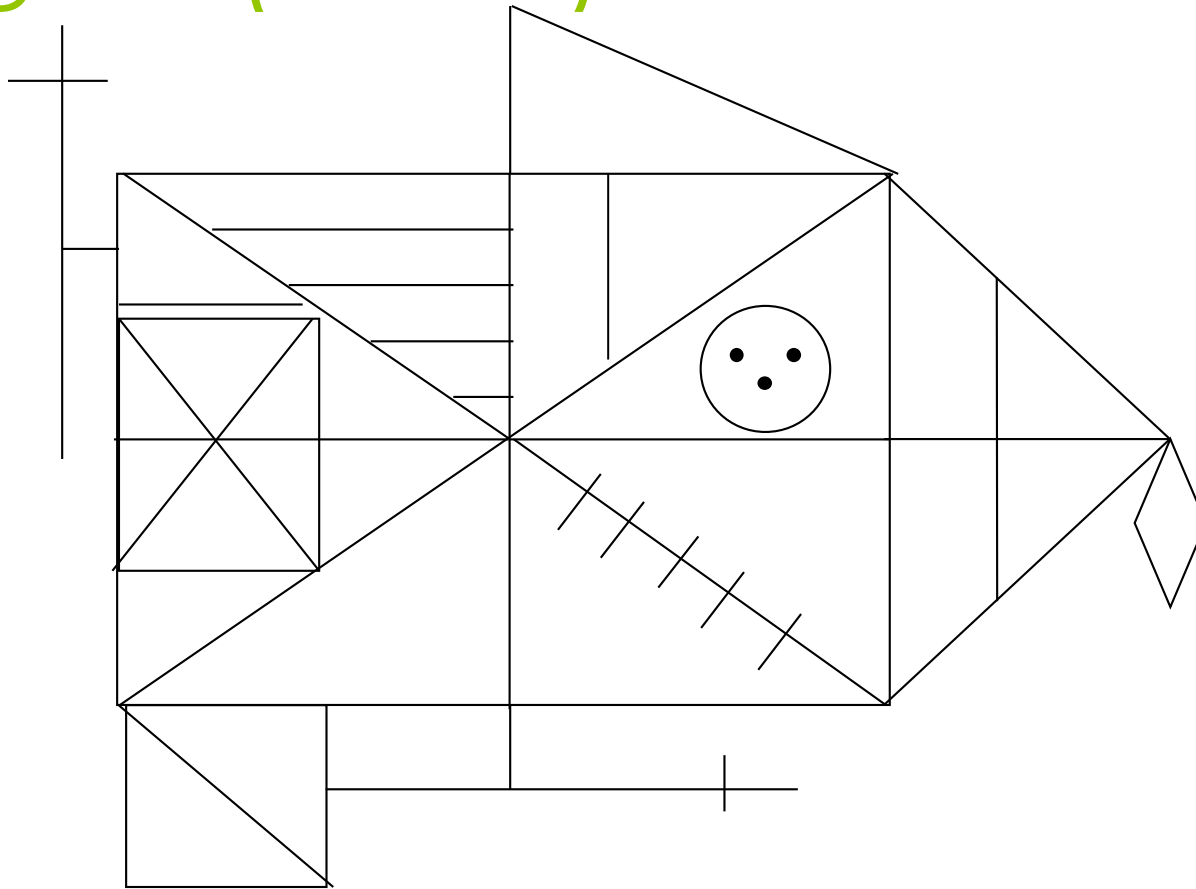

Global-to-Local Encoding Strategy Training

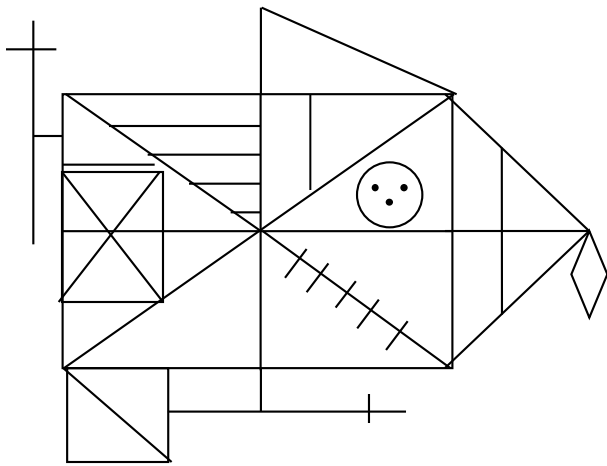

1. Copy and Immediate Recall
2. ROCF components were presented one at a time.
3. Participants traced each component until entire ROCF was shown.
4. Immediate Recall after training (IPTR)
5. Steps 2, 3, 4 repeated 5 times
6. Non-visuospatial tasks
7. Delayed Recall

Non-Structured Repetition

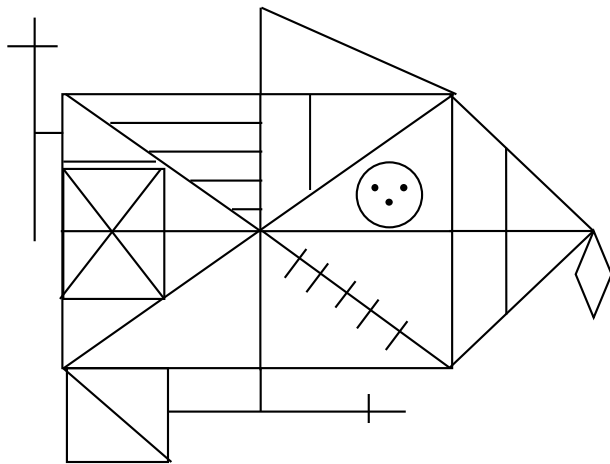

1. Copy and Immediate Recall
2. Entire ROCF was presented
3. Participants traced ROCF
4. Immediate Recall after training (IPTR)
5. Steps 2, 3 and 4 were repeated 5 times
6. Non-visuospatial tasks
7. Delayed Recall

Scoring Method

- Accuracy

- Maximum = 36

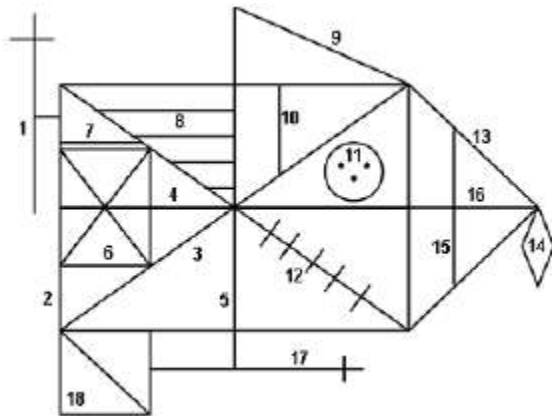

L. B. Taylor scoring criteria
(Chiulli et al., 1995; Strauss et al., 2006)

- Organization

- Maximum = 1

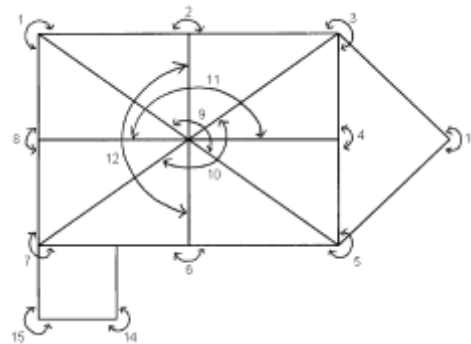

Perceptual cluster ratio = # of juncture
present / # of juncture attempted
(Shorr et al., 1992)

All ROCF copies and recalls were scored by two independent raters with .97 inter-rater reliability.

Data/Results

Accuracy

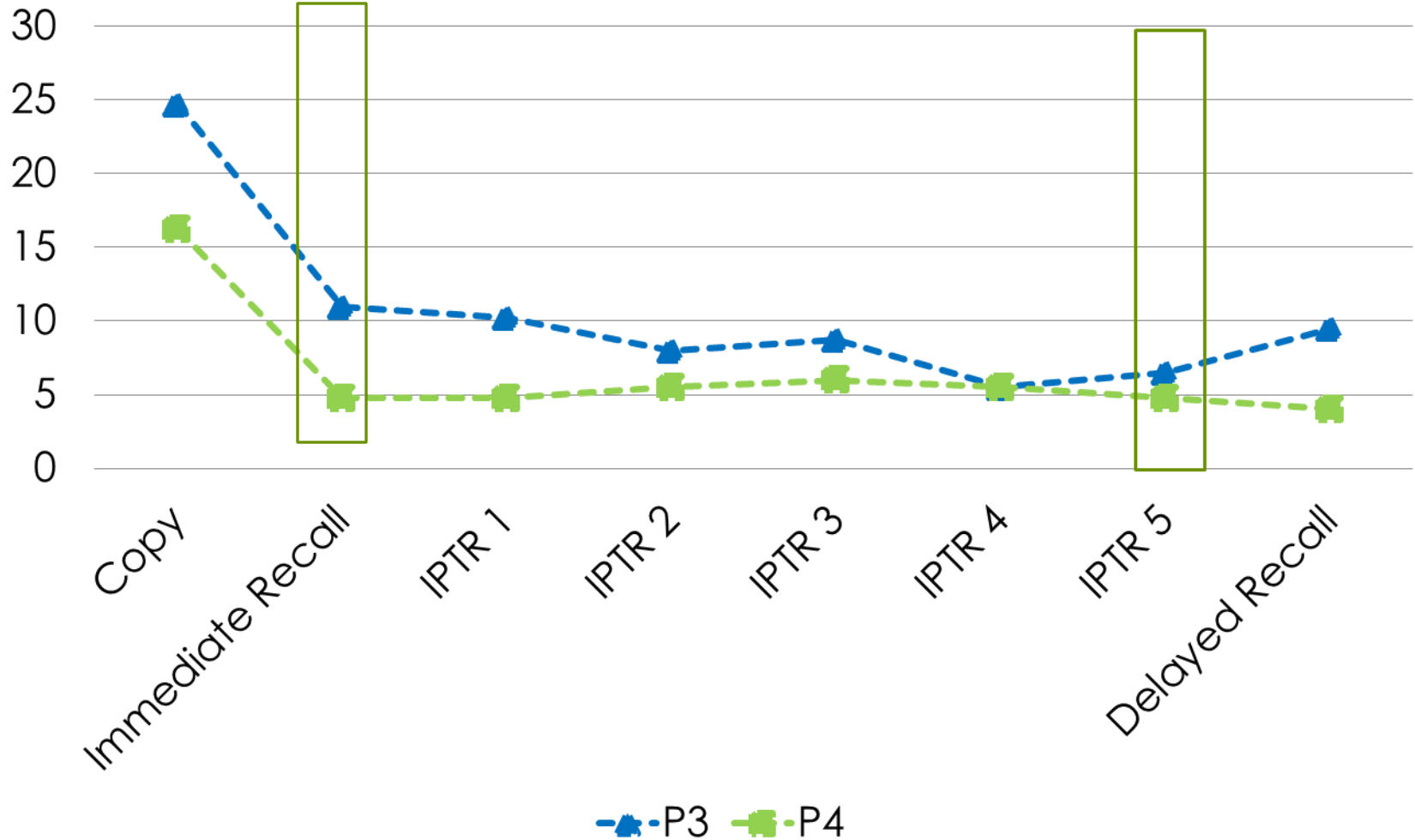

Data/Results

Accuracy

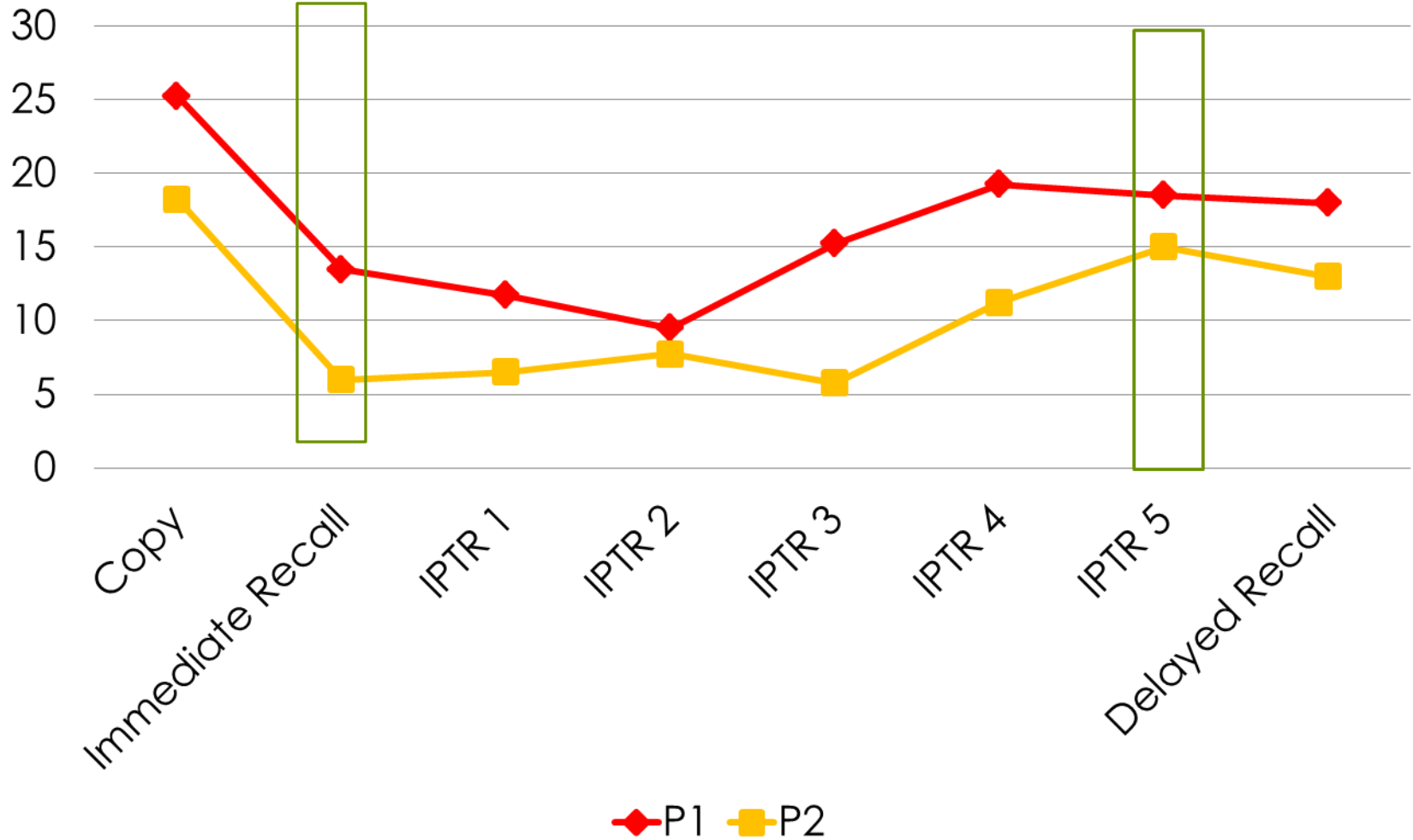

Data/Results

Accuracy

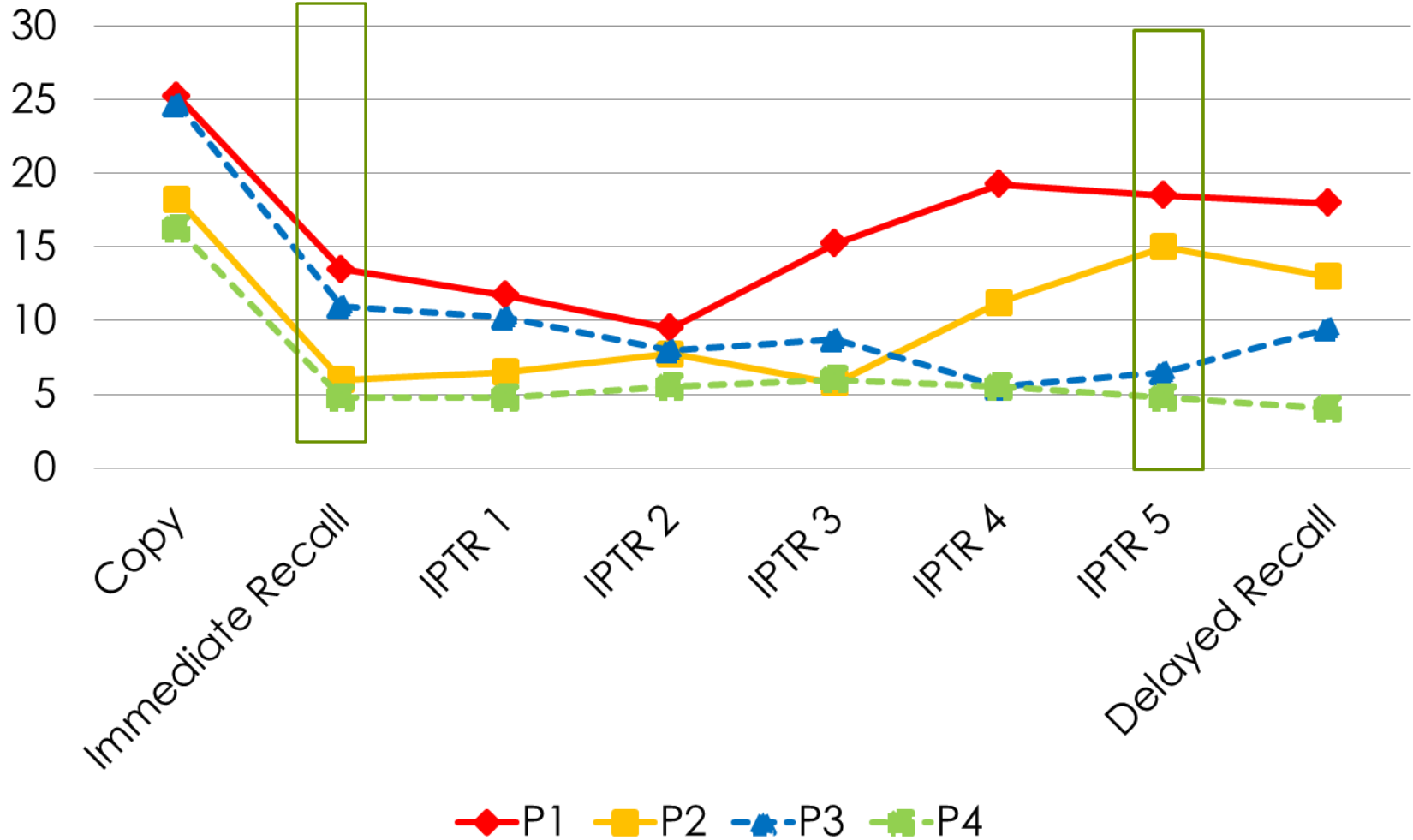

Data/Results

Organization

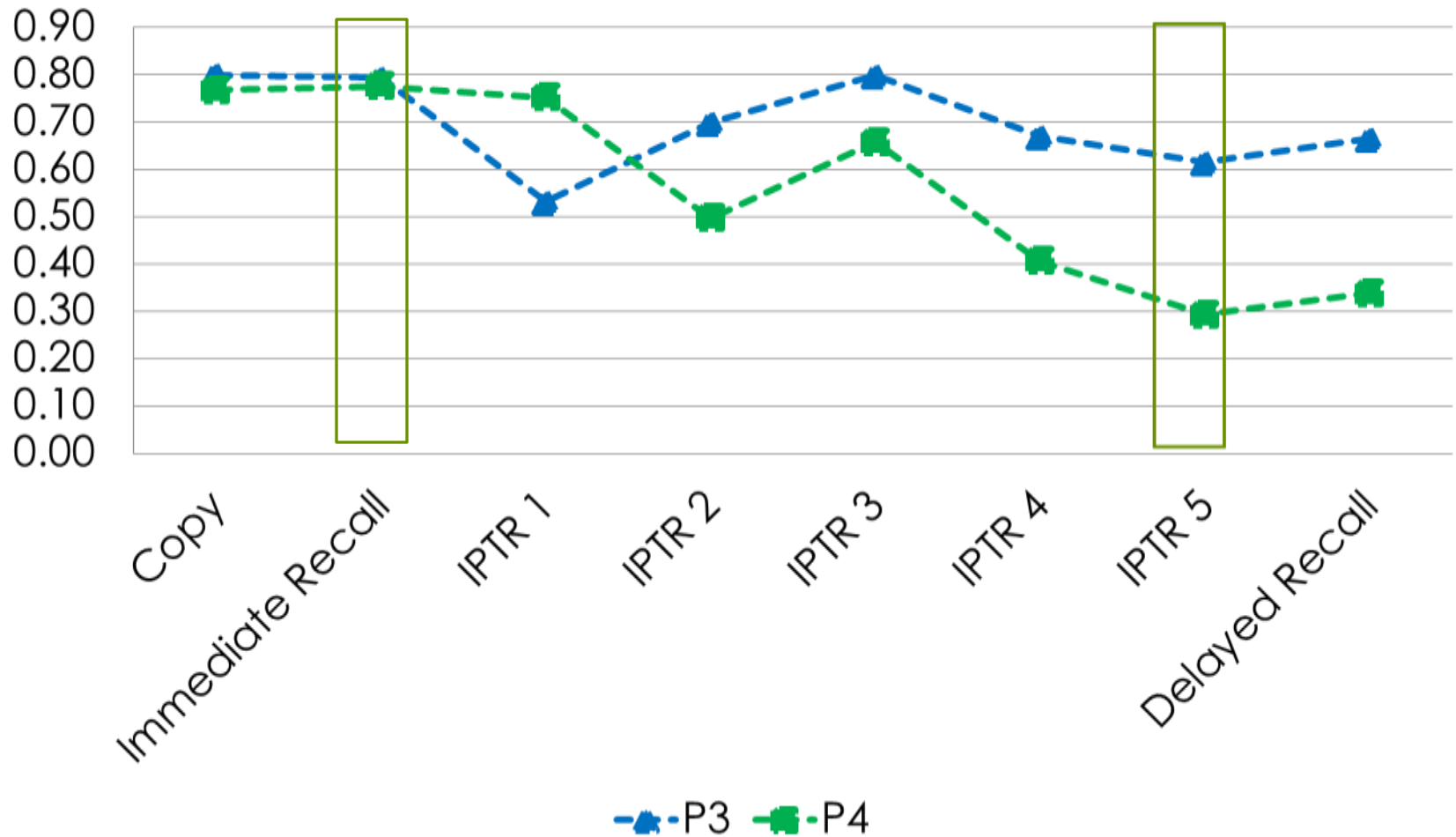

Data/Results

Organization

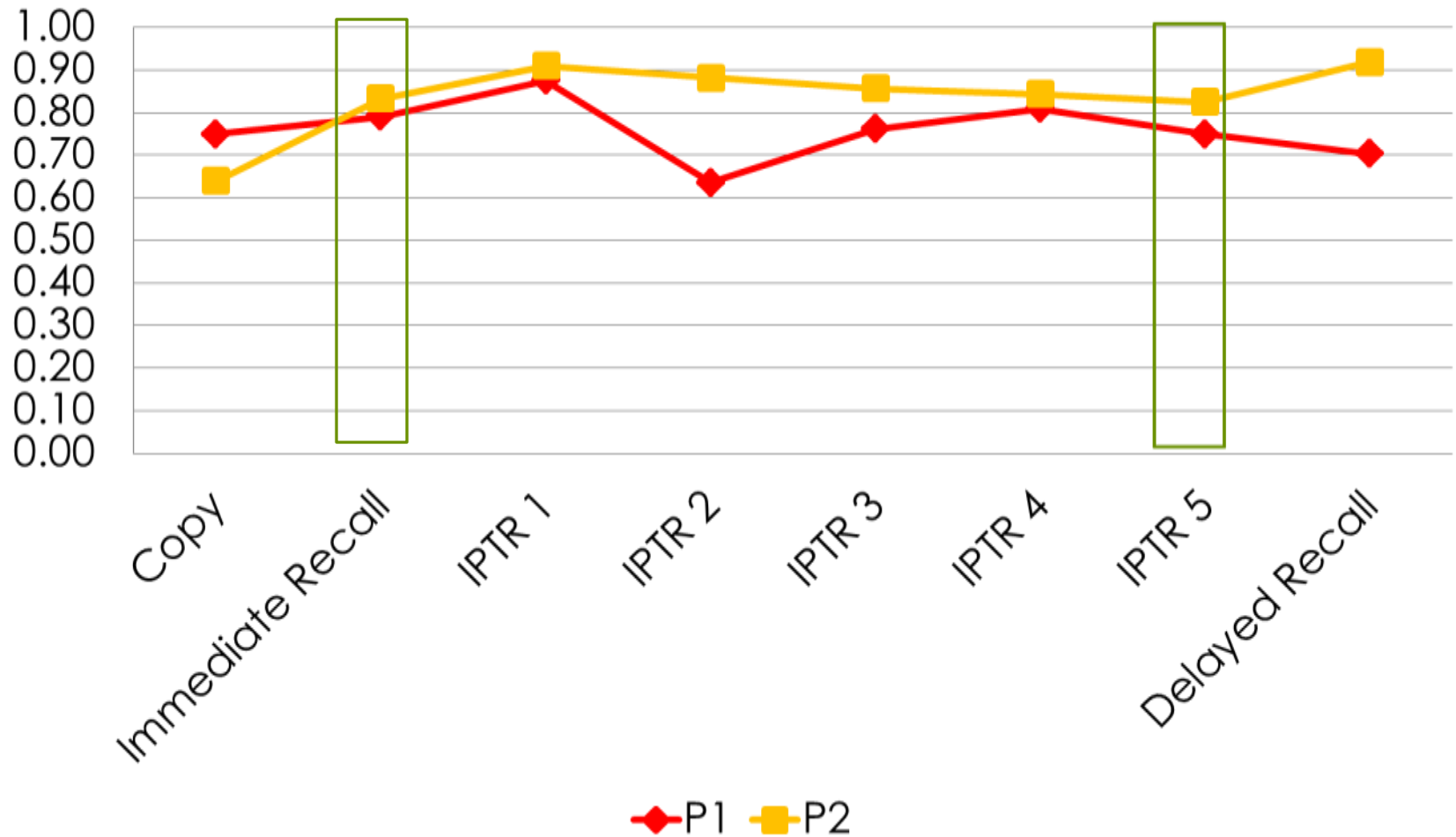

Data/Results

Organization

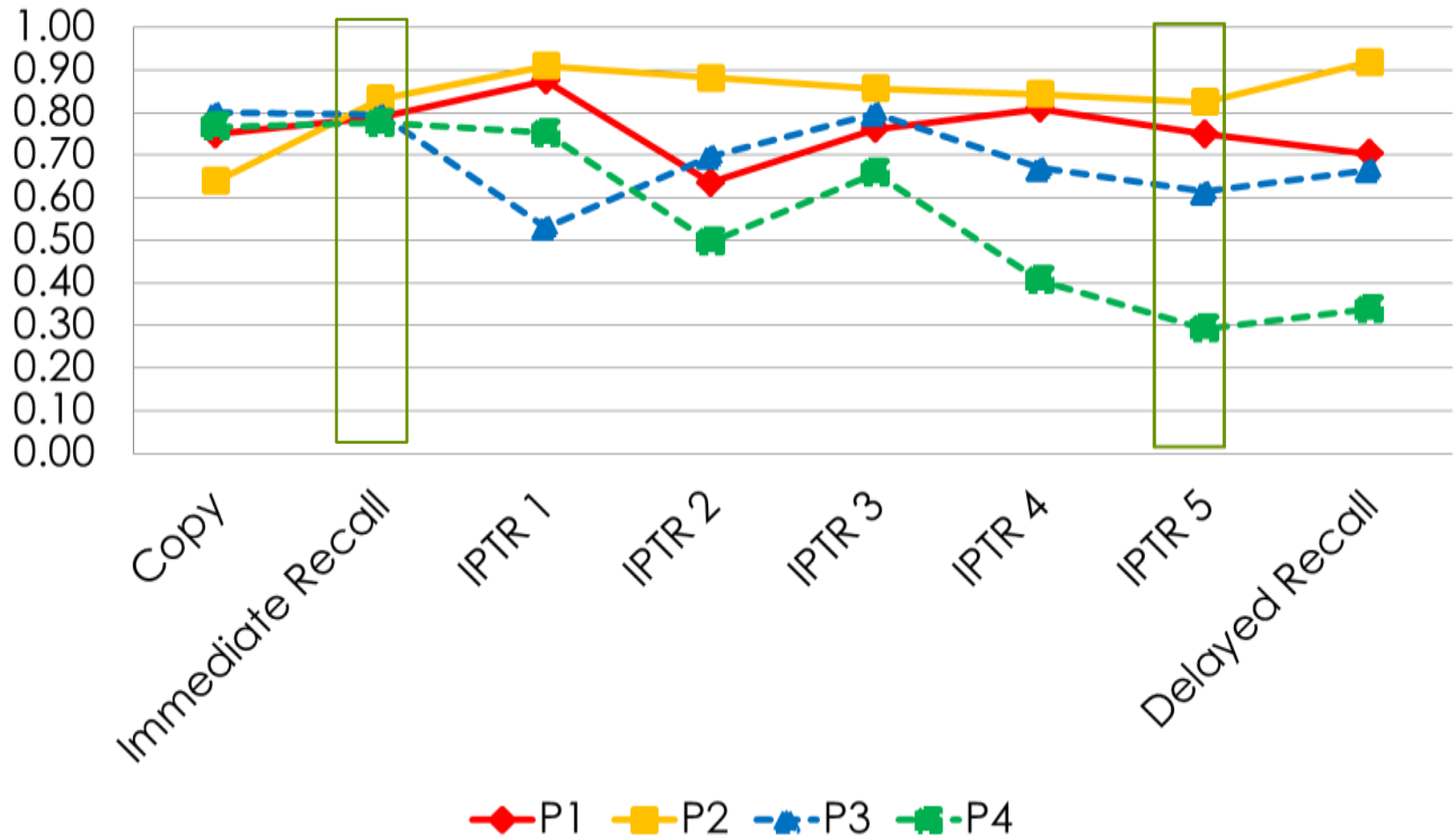

Global Strategy Group

Immediate Pre-
Training Recall

Immediate Post-
Training Recall #5

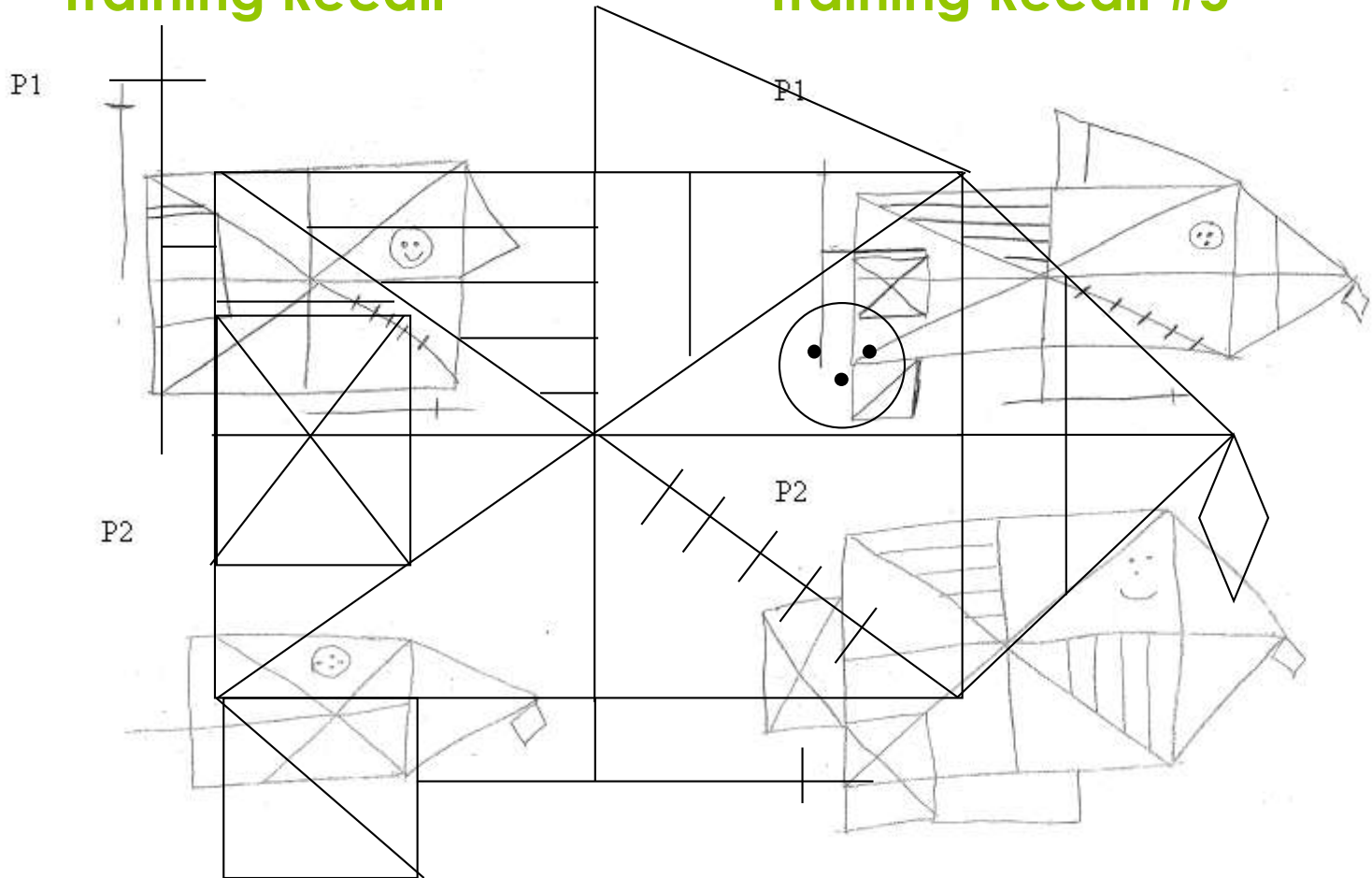

Non-Structured Repetition

**Immediate Pre-
Training Recall**

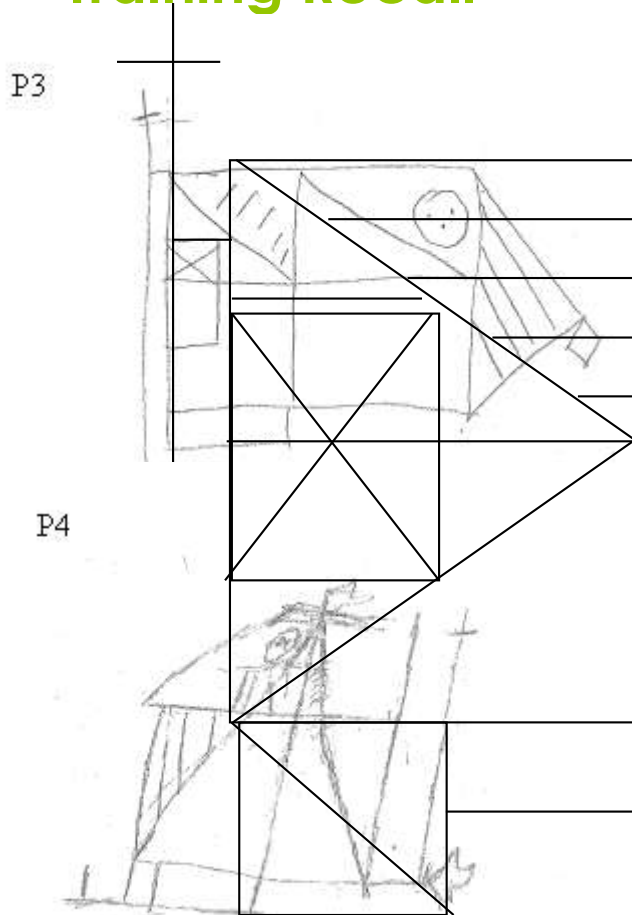

**Immediate Post-
Training Recall**

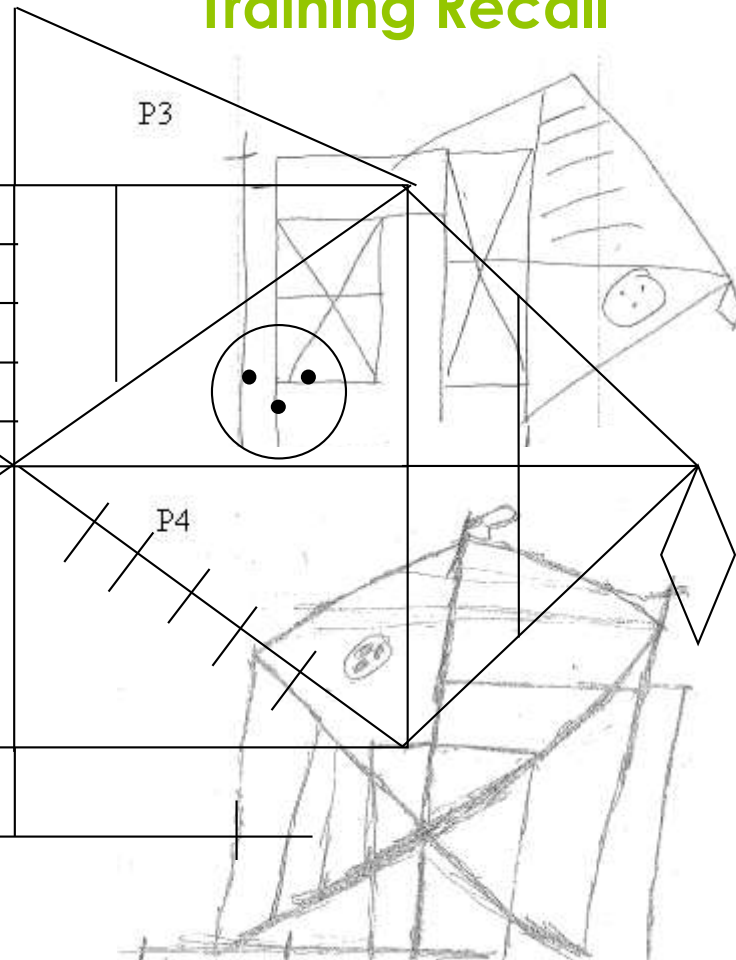

So what?

- This data is consistent with previous research
- Supports use of structured learning technique to promote overall understanding and/or recall of visuospatial information
- Global visuospatial process training vs. simple repetitive practice
- Future research
 - Memory or Attention

The “Big Idea!”

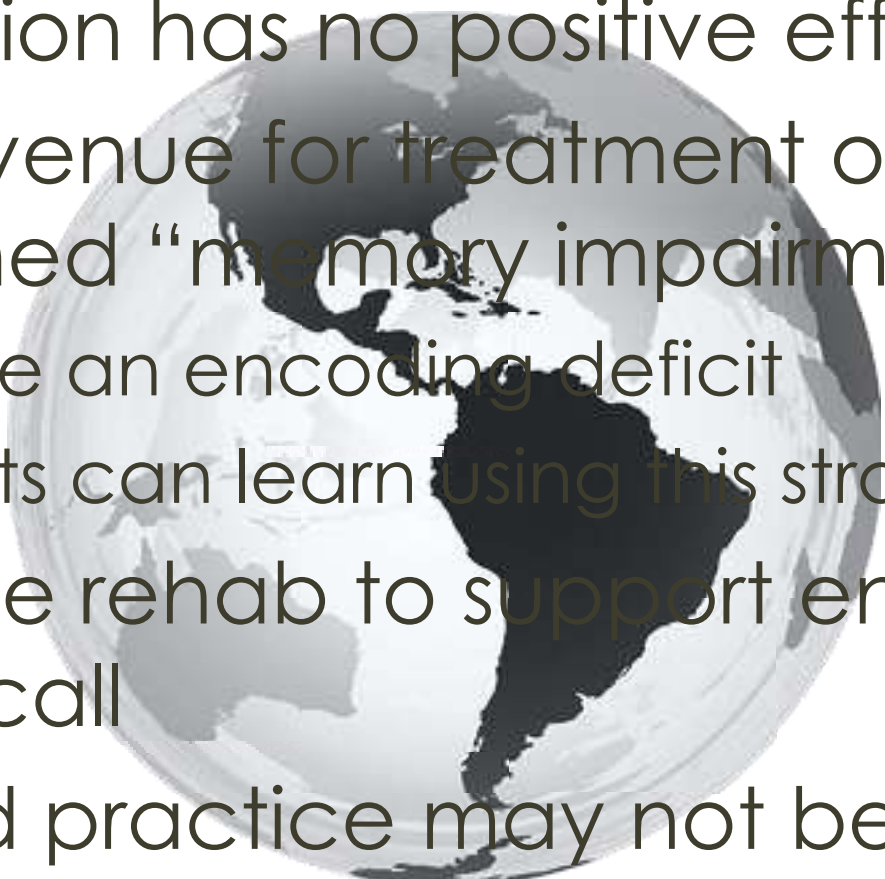
- Repetition has no positive effect
 - New avenue for treatment of presumed “memory impairments”
 - May be an encoding deficit
 - Patients can learn using this strategy
 - Reframe rehab to support encoding and recall
 - Massed practice may not be enough
- 

Presenter Disclosure Information

- Peii Chen, PhD – Kessler Foundation Research Center; University of Medicine and Dentistry of New Jersey
- Nicole Spaldo, MS, OTR/L – Kessler Institute for Rehabilitation
- Sponsored by the NICHD/NIH Grant 1R03HD063177-01